

THE RECORD PLAYER

Reference Tonearm



User & Setup Manual

General Use

User Manual

Introduction

Thank you for your purchase of the Vertere Reference Tonearm. Please study these instructions carefully. Your Reference Tonearm is designed and manufactured to the highest standards and its correct installation will enhance the sound quality of your record playing system to a new world class level rewarding you with many years of listening pleasure.

Guarantee

Your Vertere Reference Tonearm is guaranteed against any defect in materials and workmanship for a period of two years from the date of purchase. You can extend this period to **ten years** by registering your warranty on the Vertere website - vertereacoustics.com

Make a note of the serial number(s) on your warranty card for future reference - please retain the card

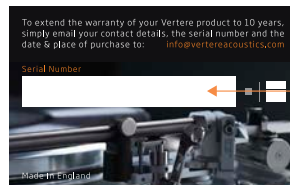

Serial Number(s)

This guarantee excludes:

1. Damage caused due to accident, misuse, neglect and incorrect installation, adjustment or repair.
2. General wear & tear.
3. Liability for damage or loss during transit from the retailer or purchaser to Vertere or its authorised distributor for the purposes of repair or inspection.

Carriage costs to Vertere shall be borne by the consignor.

All claims under this guarantee must be made through an authorised Vertere retailer. If equipment returned for repair to Vertere is found on inspection to comply with the product specification Vertere reserves the right to make a charge for examination and return carriage.

There are no user serviceable parts inside your Vertere Reference Tonearm.

Unauthorised servicing will void this guarantee.



Maintenance & Cautions

IMPORTANT

After clipping the arm in, placing the stylus guard on and switching the amplifier off, the tone arm may be cleaned with a lightly dampened soft cloth or soft brush.

Take extreme care not to damage the cartridge stylus, any parts of the tonearm main bearings, the articulated counterweight or any other part by applying excessive force on. It is important to handle the tonearm only by holding the parts marked 'Safe to Handle'.

Do not undo or tighten any of the screws which are indicated as 'Not User Serviceable Part' in the following pages.

Do not apply undue force on any of the user adjustable screws or parts.

Do not use abrasives or solvents on any parts of your Reference tonearm.

Page 2

Unpacking

Upper Tray

Your Vertere Reference Tonearm upper tray comes packed with:

- 1 Main Tonearm
- 2 Mounting Base & Fixing Ring
- 3 Accessory Pack: Base Fixing Bolts (x3), Cartridge Fixing Screws (x2) & Protractor Locating Pins (x2)
- 4 Standard Counterweight & Discs
- 5 Tungsten Carbide Loaded Heavy Counterweight & Discs
- 6 Alignment protractor
- 7 Accessory Pack: Tools

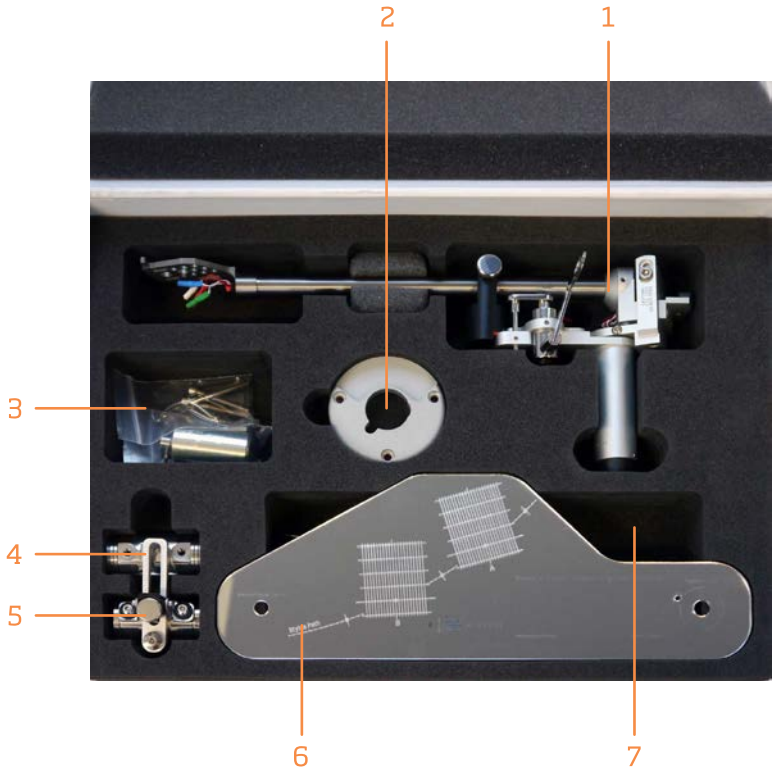

How To Handle Your Reference Tonearm

IMPORTANT

To remove the arm from its packing tray and every time handling it you should observe the following to avoid damage to the critical parts of the tonearm especially the delicate metal/polymer film bearings.

See Page 5.

Unpacking

Lower Tray

Your Vertere Reference Tonearm lower tray comes packed with:

- 1 Mains Battery Charger With UK, EU & US detachable mains plugs
- 2 Reference Tonearm Cable (Length & termination is optional)
- 3 Illumination LED Power Supply (Battery operated)
- 4 Batteries (x4 Rechargeable- AA)

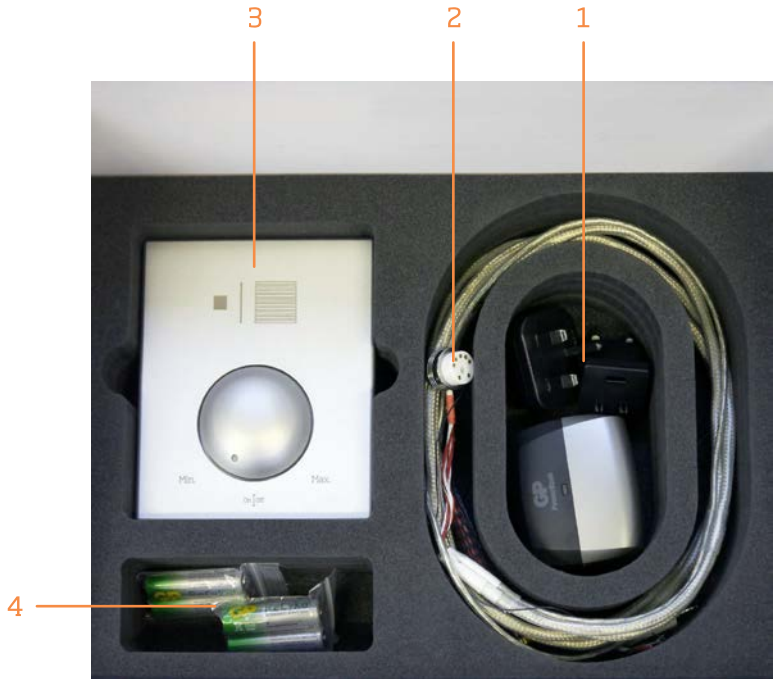

How To Handle Your Reference Tonearm

IMPORTANT

To remove the arm from its packing tray and every time handling it you should observe the following to avoid damage to the critical parts of the tonearm especially the delicate metal/polymer film bearings - effectively the moving parts of the tonearm.

The arm pillar and lift/lower plate are rigidly attached to each other and will not put any pressure onto the bearing structure thus making them perfect places to hold the tonearm from - see below.



The arm tube is best left clipped in the arm rest clip with its retaining screw securing the tube until you need to manoeuvre and move the arm/rube around.

Later when you are about to fit the cartridge and/or attach the counterweight assembly, there will be further instructions on how and where to hold the arm safely for that procedure.

Please note in most cases during set-up, the lift/lower plate would be the best place to hold and manoeuvre the arm from.

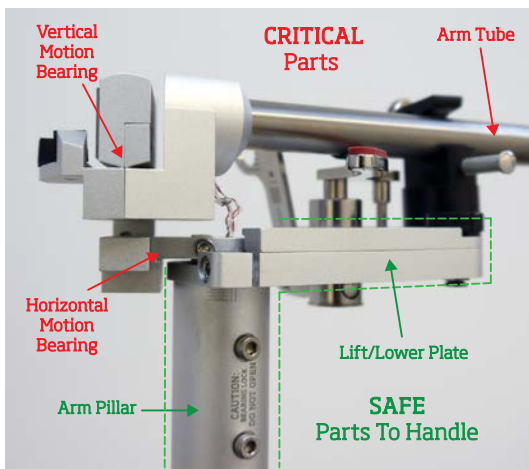

Mounting The Arm Base

SET-UP

Remove the alignment protractor and the two locating pins from the top packing tray and assemble as shown - see below.

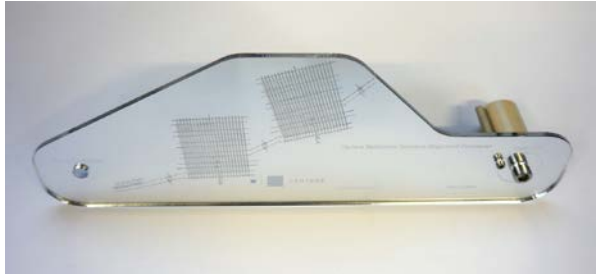

Next remove the mount base, fixing ring and bolts from the tray and fit to the arm board.

If using a Vertere SG-1 or RG-1 record player, the arm board supplied will be pre-cut for use with the Reference Tonearm.

Please note the red silicone pads face the arm board and the three fixing bolts should be done up finger tight at first - see opposite.



Fixing Ring

Mount Base

Now fit the arm board to the record player and align using the protractor. The locating pins ensure the correct centre to centre distance and angle of mount base. If on installation the angle/orientation of the arm in the mount base proves not to be as shown then remove the smaller pin and slightly rotate the mount base for suitable arm orientation.

Mounting The Arm Base

SET-UP

Fit the alignment protractor onto the record player centre spindle and the two locating pins into the mount base pillar hole as shown. Position the 'loose' arm board so that the protractor is straight and flat and not bent and under strain. This will ensure the distance between the two centres is exactly 222.5mm.

Please note the smaller locating pin orientates the arm base defining the position of the tonearm relative to the record player. Removal of this smaller pin allows rotation of the arm base around the larger locating pin facilitating the re-orientation of the tonearm if required while still keeping the centre to centre distance the same.

Once you have achieved correct orientation and distance the arm board fixing bolts can be fully tightened.

Please note the arm base fixing bolts should be tight enough to avoid any undue movement of the arm base but not be over tightened.

Arm base fixing bolts are later used to fine adjust the azimuth of the tonearm. This is achieved due to the slight flexibility in the silicone pad of the base which compresses ever so slightly when a fixing bolt is tightened gradually.

See Tonearm Set-up.

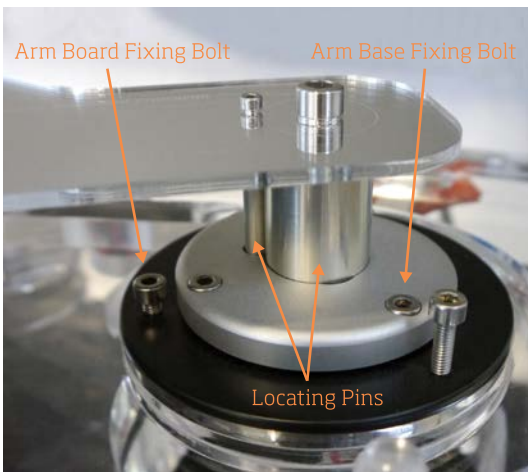
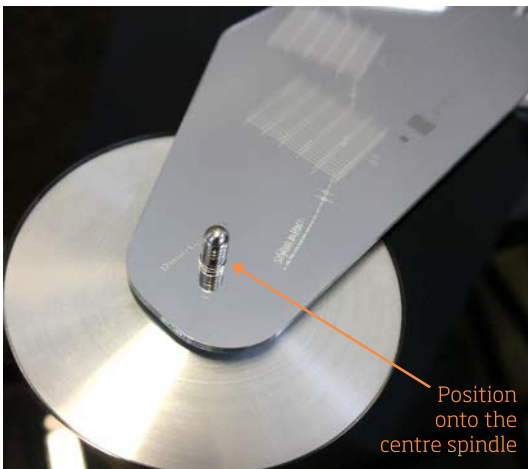

User Manual

IMPORTANT

There are two arm clip & locking mechanisms for the Reference Tonearm.

Please see opposite and use the corresponding release and locking method.



Mounting The Cartridge

SET-UP

Carefully remove the arm from its packing by holding the Main Pillar.

Leave the arm tube clipped in place and retained by the arm clip.

Have the cartridge you are intending to fit at hand and leave its stylus guard on for extra protection.

Using the high quality Titanium cartridge thumb screws supplied, mount the cartridge to the head-shell but do not fully tighten the screws just yet.

Take care to connect the cartridge tags correctly in accordance with the cartridge manufacturer's instructions. Be especially careful with the internal wiring of the tonearm when connecting to the cartridge pins or fly leads.

DO NOT exert undue force on the wires or the cartridge tags by use of pliers.

The stylus tip should be set directly below the front edge of the head-shell and the body of the cartridge should be aligned parallel with the side edge. This way the alignment and the overhang would be almost done and ready to be checked using the supplied protractor.

The arm pillar can now be fitted to the arm base on the arm board.

Please note at this point the counterweight assembly is not yet fitted and the arm/cartridge should not be lowered onto the record, stylus balance or platter surface as this will damage the cartridge. The VTA adjustment/pillar fixing screw should be undone sufficiently to allow the tonearm pillar to easily slide into the pillar holder.

To place the arm pillar into the base the pillar connector fixing screw has to be aligned with base pillar hole cut-out to allow the pillar to slide into the hole until the larger screw head comes into contact with the base. Now **carefully** rotate the arm until the screw head lines up with the hole cut-out - See below.

To avoid damage to the cartridge, please exercise caution while carrying out this task.

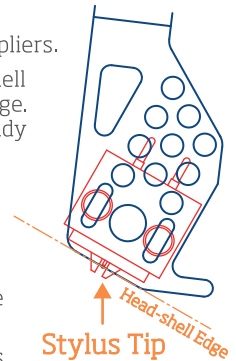

NOTE: At all times hold the tonearm by the lift/lower plate and avoid any pressure on the bearings and the arm tube.

You can tighten the VTA adjustment/pillar fixing screw once the arm is approximately in the required position and height. Please note this screw should be just tight and not fully tightened yet as later you will require to do final VTA adjustments.

Fitting The Counterweight Assembly

SET-UP

There are two counterweight blocks supplied with your Reference Tonearm.

- 1 Standard Stainless Steel Weight & End Discs
- 2 Heavy Weight (S/S Tungsten carbide loaded) & End Discs

Standard C/W

Main Block: 142g
End Discs: 7.5g

Use the standard counterweight with light to medium weight cartridges.



Heavy C/W

Main Block: 195g
End Discs: 12.5g

Use the heavy counterweight with medium to heavy weight cartridges.



The counterweight beam has a precision ball race bearing that allows the entire assembly to move side to side. This is fixed to the end of the vertical motion bearing yoke. The yoke has a threaded hole and two side stops lined with thin strips of foam that limit and dampen the movement of the beam. The counterweight beam bearing has attached to it a fixing screw that threads into the bearing yoke securing the counterweight assembly in position.



NOTE: The counterweight assembly must be fitted to the bearing yoke with care and caution to avoid undue force on any of the bearing components and yokes. The C/W beam fixing screw should not be over tightened as this will twist and strain the delicate main tonearm bearings.

Carefully locate the C/W beam bearing fixing screw onto the yoke threaded hole and using the 2.5mm A/F Allen key gently tighten the screw. Take care not to push down twist the bearing yoke inadvertently. If necessary, support the yoke from the underside once the screw is about to reach its fixing position. This will relieve the bearing yoke of any unwanted strain.

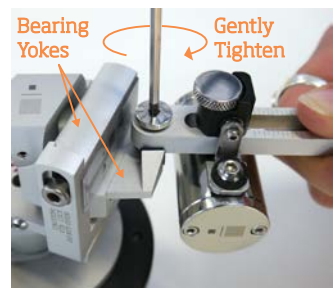

Setting Tracking Weight

SET-UP

The counterweight assembly can move along the beam towards the bearing yoke to increase tracking force or move away from the bearing yoke to reduce tracking weight. Its position is fixed by the locking thumb nut screw on the counterweight black Acetal carrier. Note the counterweight block is attached to the carrier by two swing brackets. These are fixed to the carrier by two screws on the sides via two precision ball race bearings that allow the assembly to freely swing back and forth.

The tightness of these two screws determines how freely the assembly swings.

DO NOT undo or over tighten these two screws. In normal use these should be done just finger tight.

To increase the damping on the swing, you can tighten the screws by a **maximum** of a 1/4 turn on each screw. But do not slacken beyond finger tight.

As the counterweight assembly of the Reference Tonearm is designed to dynamically alter tracking weight to assist with record warp, it is important to check and set tracking weight at record height and platter being level - See below.

Most electronic stylus balances are actually about a record thickness above the platter when used on the platter itself. Using such a stylus force gauge, check the tracking force and then adjust the counterweight assembly and set it according to cartridge manufacturer's instructions. Please note after cartridge alignment and final VTA settings the tracking force must be re-checked and re-adjusted as required.

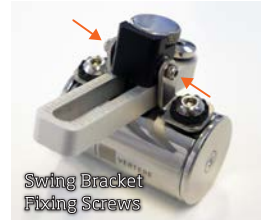

Gently support the beam and unlock the thumb screw until the carrier can move freely along the beam. Now gently re-position the carrier towards or away from the bearing yoke to increase or reduce the tracking force and re-check using the stylus force gauge. Repeat until it is approximately set as per cartridge manufacturer's instructions.

A Fine Tracking Weight Adj. Screw is also supplied which can also be implemented from the start when fitting the C/W assembly. Using this will allow much finer changes to the tracking weight - see below.

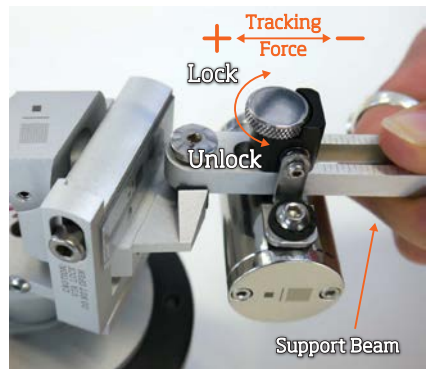

Cartridge Alignment

SET-UP

Cartridge azimuth must be checked and adjusted (if required) before you align cartridge horizontal and vertical tracking angles.

Correct azimuth is when the cartridge sits parallel to the record surface when viewed head-on from the front - see below.

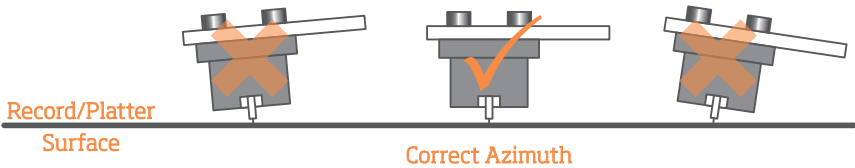

The azimuth is adjusted by tightening the pillar base fixing screws as shown. As screws 1 & 2 are tightened (+), they lower the base at that side and in turn changing the azimuth of the cartridge by a small amount. As long as the arm board and the platter of the turntable are not too far out of alignment with each other, adjusting these two screws would be more than sufficient to set the azimuth of the cartridge.

Please note these screws should be quite tight and never slack. Just one screw to be tighter than the other to achieve correct azimuth. Once this is achieved, the 3rd screw should be tightened. This screw does not affect the azimuth.

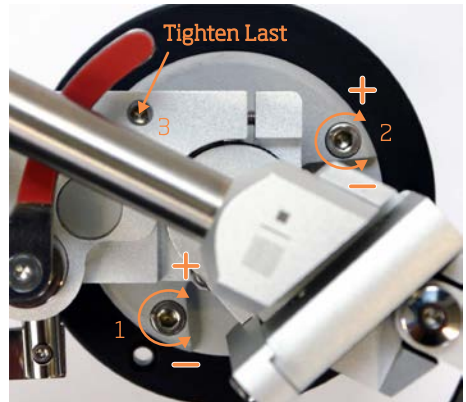

NOTE: If for any reason fine adjustment of these screws does not achieve correct azimuth then please contact your retailer/distributor or Vertere for further instructions.

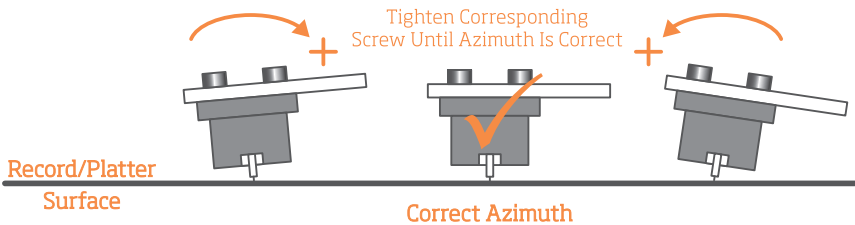

Cartridge Alignment

SET-UP

Now place the alignment protractor provided onto the main spindle and carefully locate the arm/cartridge on it lining up the stylus tip with the marked stylus path arc as shown. When the cartridge is mounted in its correct position in the head-shell, the stylus tip will track along the marked stylus path and be aligned perfectly to the grid on A and B. See below.

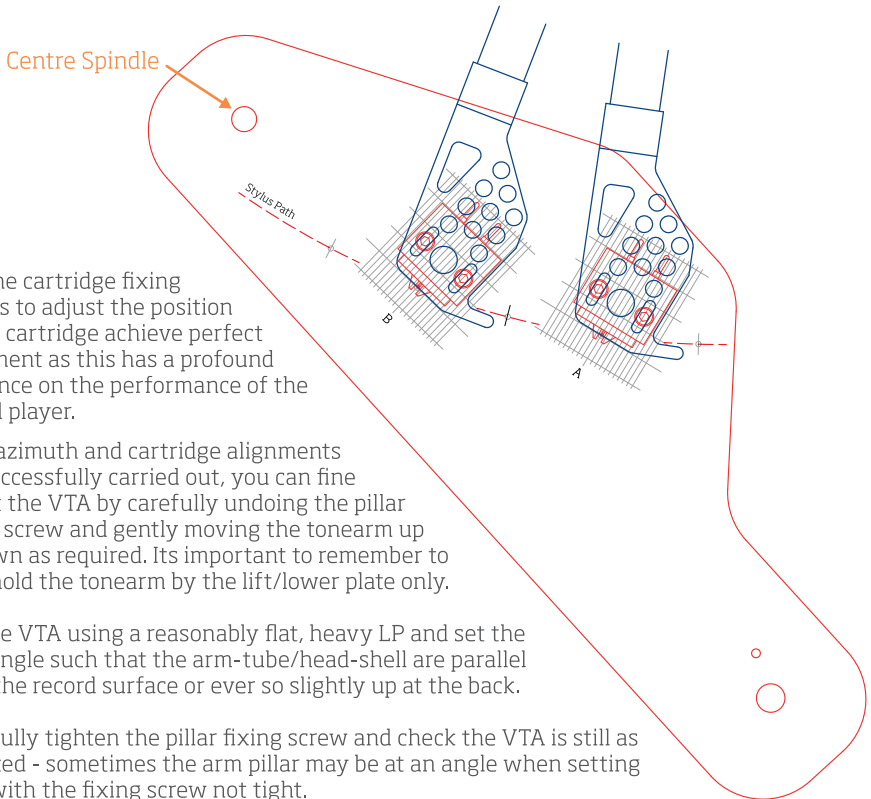

Use the cartridge fixing screws to adjust the position of the cartridge achieve perfect alignment as this has a profound influence on the performance of the record player.

Once azimuth and cartridge alignments are successfully carried out, you can fine adjust the VTA by carefully undoing the pillar fixing screw and gently moving the tonearm up or down as required. Its important to remember to only hold the tonearm by the lift/lower plate only.

Set the VTA using a reasonably flat, heavy LP and set the VTA angle such that the arm-tube/head-shell are parallel with the record surface or ever so slightly up at the back.

Now fully tighten the pillar fixing screw and check the VTA is still as adjusted - sometimes the arm pillar may be at an angle when setting VTA with the fixing screw not tight.

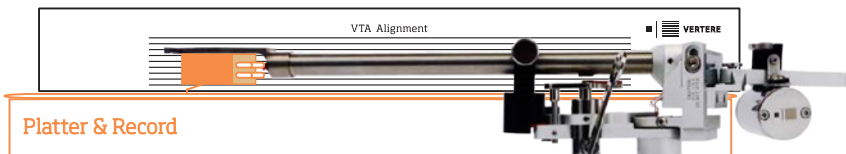

Platter & Record

VTA Final Adjustment

SET-UP

VTA adjustment is carried out mainly using the VTA/Pillar fixing screw. There is however a 'VTA Lock' screw located on the side of the vertical motion bearing support and normally should be left as factory set.

You may however use this screw (With great care - once and not repeatedly) for final VTA adjustment.

With 'Great Care', because this screw must **always** be reasonably tight but when it is being loosened (Fractionally) or tightened for adjustment, there should be **No Undue** force exerted on the bearing yokes and the main bearings of the tonearm.

If and when attempting to use this screw for final VTA adjustment, ensure that the yokes and the bearings are **gently** and yet **firmly** supported with one hand while the the screw is being loosened or tightened to avoid any force or pressure being transmitted to the bearings - see opposite.

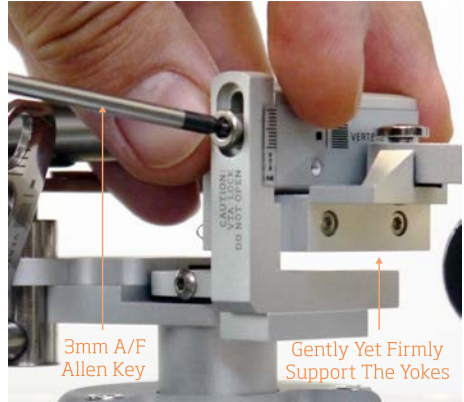

IMPORTANT:

If in any doubt, use the VTA/Pillar Fixing Screw as this is perfectly adequate to set the VTA accurately.



Finally, with cartridge alignment and VTA set, re-check the tracking force and adjust as required.

Anti-skate Force Adjustment

Anti-skate or Bias adjustment is carried out by the anti-skate dial as shown. It is advisable to use a test record with tracking ability or bias setting on it but it can also be set without a test record.

Initially set the dial at the same value as the tracking force. Next use a record and play it near the middle of the record. Gently lower the stylus onto the record and allow the lift/lower to settle fully down while the stylus is tracking. Next gently and slowly lift the arm/cartridge off the record using the lift/lower cueing device and observe the stylus/cantilever closely and from the front - head-on.

When the anti-skate force is set correctly, the stylus/cantilever will lift off the record without any sudden shift to one side or the other. This indicates the anti-skate force is equal and opposite to the inward skating force.

If however the stylus/cantilever shift inwards as they lift off the record then the anti-skate force is insufficient and requires increasing.

Vice versa, if the stylus/cantilever shift outwards, then the anti-skate force is too high and requires reducing.

Repeat this near the edge and again near the centre of the record for verification of the anti-skate force throughout the record.

If in doubt, consult your retailer/distributor or Vertere.

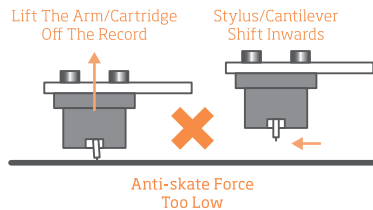
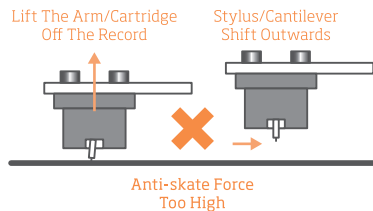
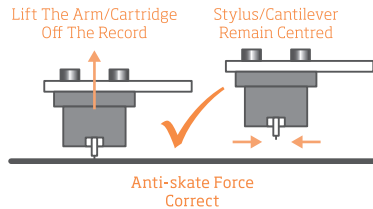

Tonearm Cable & Plug

SET-UP

The reference tonearm utilises a proprietary 7-Pin connector for audio signal and the illumination LEDs.

A matching Vertere proprietary 7-Pin connector is also fitted to the Reference Pulse Hand-built tonearm cable. Make sure the tonearm cable is secured to the record player as per manufacturer's instructions. Allow sufficient slack in the stripped back section of the tonearm cable just before the 7-Pin connector. This is to minimise unwanted structural vibrations reaching the tonearm.

It is also important to ensure the very delicate thin wires of the hand-built cable are not damaged or broken.

Carefully align the tonearm cable connector with the one on the tonearm and plug it in. The contacts are precision made and do not require excessive force to make the correct connection. A gentle push fit is all that is required.

Once the cable is connected to the tonearm, plug in the phono amp signal connectors and attach the grounding spade connector to the amp chassis as per amplifier's instructions.

Finally connect the 3.5mm Jack connector of the LED power cable to the LED power supply.

The LEDs are turned on and off by simply pushing the dimmer dial and are brightness adjusted by turning the dial clockwise and anti-clockwise.

The supplied re-chargeable batteries will last about a month of normal use before requiring a re-charge. Use the supplied charger to re-charge the batteries.

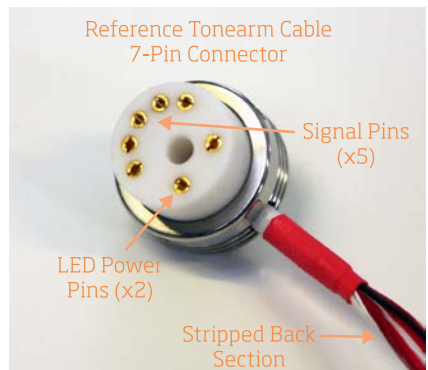

The arm clip on the reference tonearm has a thumb screw that can be used to secure the arm tube in place when re-positioning or moving the record player.

It is Important to leave the thumb screw in the 'Release' position for normal use. This will allow the arm to be moved in and out of its rest position without the clip pinching the arm and avoid undue force on the bearings.



Specifications

Type		Pivoted
Effective length	240mm	Horizontal
	263mm	Vertical
Overhang		17.5mm
Offset Angle		22.9°
Head-shell		Titanium
Arm Tube		Titanium
Bearing Yoke Structure		Aluminium Alloy
Bearing Type		Non-rotating Metal/Polymer Film
Counter Weight		Stainless/Tungsten Carbide
		Articulated x3 Ball Races
Internal Wiring		Special Hand-built Pulse
		Signal & LED Power Wiring
		x3 Thickness Gold Plated Contacts
Connector		Proprietary Cartridge & Cable connectors
		x3 Thickness Gold Plated Contacts
		Vertere 7-way Tonearm Connector
Tonearm Cable		Special Hand-built Pulse
		x3 Thickness Gold Plated Contacts
		D-Fi LED Power Cable
Queuing Light Power Supply		Battery Powered
Standard Counterweight (x1)		142 g
Standard C/W Disc (x6)		Each 7.6 g
Special Counterweight (x1)		83 g
Tungsten Carbide C/W Insert (x1)		114 g
Special C/W Disc (x4)		Each 7.6g
Overall Weight (With Std C/W & x4 Discs)		Approx. 590 g



All specifications are liable to change without prior notice. E & OE
Made in England